



cove lighting

Cut Sheet #4073

TYPICAL APPLICATION MATERIALS

ILLUMINATOR:
LGE150 or LGP250

FIBER OPTIC CABLE:
F-DL-DSL-LC-3025
(brightest)
F-DL-DSL-LC-6019
(bright)

MOUNTING MATERIALS:
F-AC-T-U-W-25
(track for 3025)
F-AC-T-U-W-19
(track for 6019)
F-AC-W-15 (wedge)

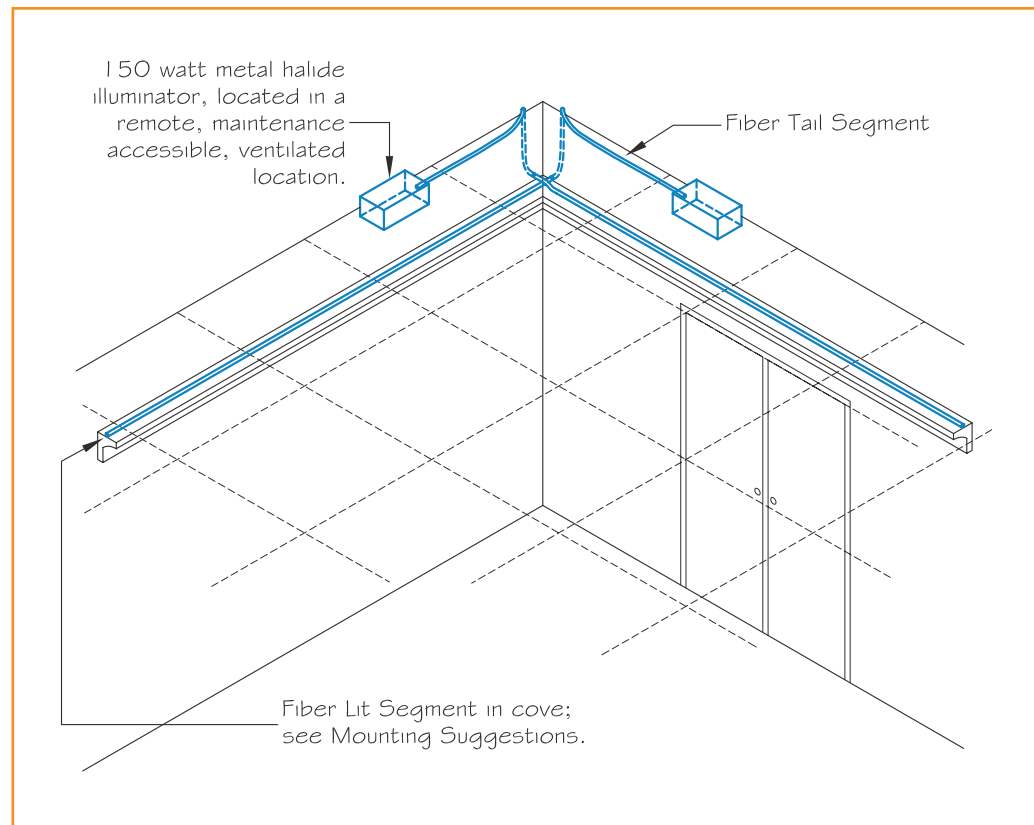

DESIGN CONSIDERATIONS

1. Diamond Line 3025 produces the brightest light output with longest effective throw distance (refer to Effective Throw Distance Chart,) but has a narrow 30° beam spread. Diamond Line 6019 produces a wider 60° beam spread, but has a shorter effective throw distance.
2. Terminating two Diamond Line 6019 fibers into one illuminator can provide a significant cost savings, but light output will be diminished by approximately 40%. Illuminators can hold only one Diamond Line 3025 fiber.
3. Due to the rigidity of Diamond Line fiber, use side-by-side fiber mounting tracks only. Mounting track can be field-cut into small segments to create curves. The 15° Mounting Wedge should be used to focus the fiber at the appropriate angle.
4. Fiber placement in relation to the aperture (opening) of the cove can greatly affect results. Using wooden riser blocks or our angled wedge can help focus the light to provide a more pronounced cove accent or a subtle ceiling wash.
5. Refer to the fiber cut sheets for recommended maximum cable lengths. Maximum lengths may vary depending on cable size, illuminator type, and termination configuration.
6. When calculating fiber lengths, specify individual lengths for the Lit Segment and Tail Segment of the fiber; also be sure to include an extra one foot service loop of cable per Tail Segment. This service loop will allow for slight changes in illuminator location or orientation, and also allows the cable to be re-harnessed in the future, if required.

INSTALLATION CONSIDERATIONS

1. Turns around room corners must accommodate the fiber's minimum bend radius. Diamond Line 3025 requires a 12" minimum bend radius, while Diamond Line 6019 requires a 9" minimum bend radius.
2. During installation, some masking of the fibers may be required to equalize the overall light output. This is typically required when the fiber bends around a corner, or at the entry point of the fiber into the cove. White tape can be applied to the fiber to reduce the light output at these bright spots.
3. A matte white finish inside the cove increases light reflectivity. Paint walls and ceilings white, or cover walls and ceilings with 3M Light Enhancement film for optimum results.

EFFECTIVE THROW DISTANCE

	LGE150	LGP250
Diamond Line 3025	6'	8'
Diamond Line 6019	3'	4'

APPLICATION

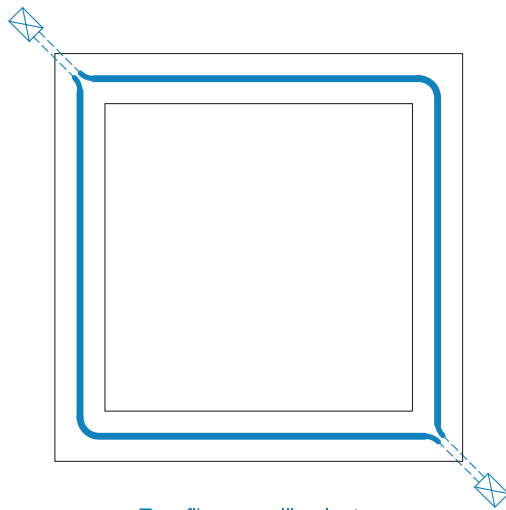

Two fibers per illuminator
(Diamond Line 6019 only)

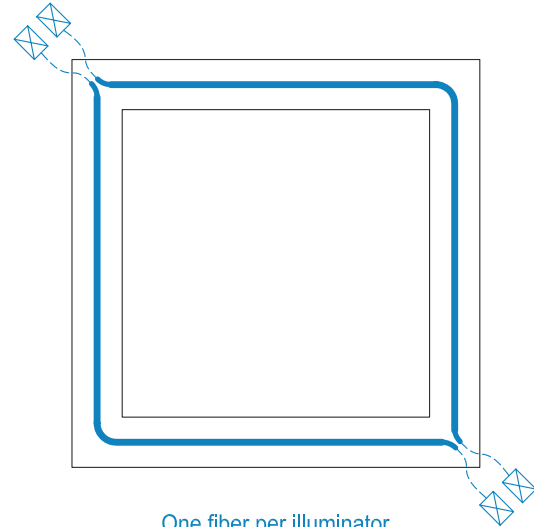

One fiber per illuminator

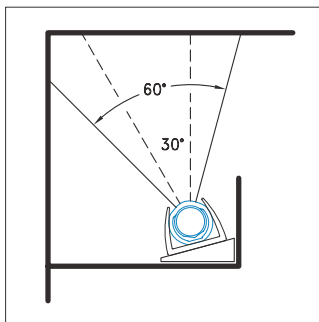

Maximum light
within the cove

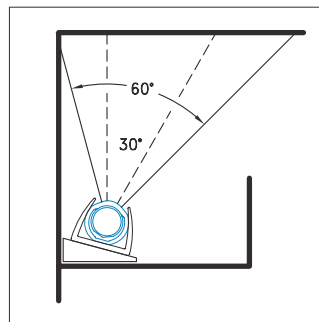

Focus on ceiling
above the cove

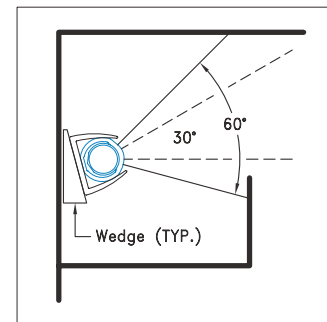

Maximum ceiling focus
outside the cove

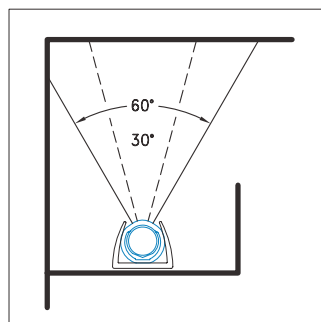

Balanced accent of
cove and ceiling

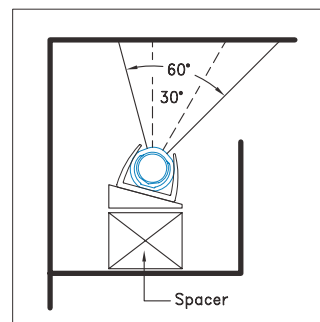

Spacer added to light
over cove return